

# SERIES HCA REPLACEMENT CHASSIS

Singer/McQuay HCA Series



ADIRONDACK-AIRE



The Adirondack-Aire HCA series zerOzone replacement chassis provides environment friendly, high efficiency cooling and heating where individual, quiet control is a priority. This application flexible unit is also a direct replacement for Singer/McQuay HC, EH (models 070, 090, 120, 140, 180, and 240) series vertical stacked water source heat pump chassis. The chassis is a part of a complete system, which consists of the chassis, blower section, control box, and furred-in room cabinet with risers. The chassis contains the compressor, air side heat exchanger, water side heat exchanger, and refrigerant circuit control and safety components.

The HCA is dimensionally identical to the original for a fast, easy, and trouble-free installation. Quality components, careful design and testing and the latest in environment friendly technology mean long unit life, user satisfaction and lower energy costs. Consider the extensive list of standard features which includes: powder painted drain pan, refrigerant circuit access ports, air filter, pull handle, compressor-protected suction accumulator, evaporator freeze protection, water coil freezestat, high-pressure over protection, and lock out circuit\*. Adirondack-Aire is the replacement solution for upgrading old, worn out, inefficient original chassis. Cold Point Corp. backs the HCA with a customer friendly one-year parts and labor warranty and five-year compressor warranty, (see Warranty document for details).

\* Model specific. May include lock out circuit, five minute anti-short cycle timer or interconnect control utilizing control panel logics.

## APPLICATION & BENEFITS



### FAST AND EASY REPLACEMENT

The Adirondack-Aire HCA series zerOzone replacement chassis fits the existing Singer/McQuay HC room cabinets and works with the existing blower section and control box without modification. Because the chassis dimensions and construction details are like the original, replacement work is fast and easy. The chassis installs without the need for water loop shut-down or draining. A chassis pull handle is provided to facilitate easy removal and handling. Water, drain and electrical connections line right up to the original installation. The electrical connectors plug directly into the control box connectors. Using Adirondack-Aire replacements eliminates the need for room renovation, redecorating, and piping changes and is the solution that gets your property back in service quickly and at the lowest total cost.



### DAMAGE PROTECTION

The standard high-pressure switch and evaporator coil freeze protection stops unit operation before damage occurs, should airflow become reduced or obstructed due to dirty coils, obstructed airflow, or motor failure or lock up. A freezestat protects the water coil from freeze damage due to water temperature or flow problems. The water coil is designed for low water-side pressure drop, eliminating potential pump sizing and water flow problems.



### OPTIONS AND ACCESSORIES

- Blower sections
- Return air panels
- Control options
- 115V, 265V/277V (Availability varies by model sizes)
- Hose kits
- Flow control valve

# SERIES HCA REPLACEMENT CHASSIS

Singer/McQuay HCA Series

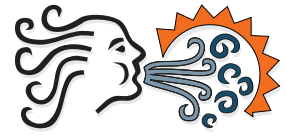

ADIRONDACK AIR

## Performance Ratings\*

Model	Cool Btuh*	Sens Btuh	EER*	Heat Btuh*	COP*	CFM (Design)	GPM	Coil PD	Refrigerant
HCA-08	8,300	5,800	14.1	9,800	4.4	250	2.0	1.2'	R-410A
HCA-10	9,800	7,200	13.4	11,900	4.2	315	2.4	1.8'	R-410A
HCA-12	12,300	9,400	12.6	15,000	4.2	400	3.0	3.4'	R-410A
HCA-15	15,600	12,100	15.6	17,500	4.6	550	3.0	3.4'	R-410A
HCA-20	20,600	15,000	14.5	23,200	4.4	635	4.5	3.2'	R-410A
HCA-24	26,000	18,800	14.6	29,100	4.4	800	6.0	6.4'	R-410A

Continuous engineering improvements may result in performance changes without notice.

\* Includes 1250Btu/1000 CFM fan heat and 365w/1000 CFM fan power. Fan power and pumping corrections are not included for rating purposes. 208v data shown. 115v and 265v ratings may vary.

## Unit Sizes

Model	A	B	C	D	E	Chassis Weight (lbs)
	Inches					
HCA-08	17 5/8	18 3/4	41	12	12 3/4	75
HCA-10	17 5/8	18 3/4	41	12	12 3/4	80
HCA-12	17 5/8	18 3/4	41	12	12 3/4	85
HCA-15	17 5/8	18 3/4	41	12	12 3/4	90
HCA-20	17 5/8	18 3/4	41	12	12 3/4	105
HCA-24	17 5/8	18 3/4	41	12	12 3/4	125

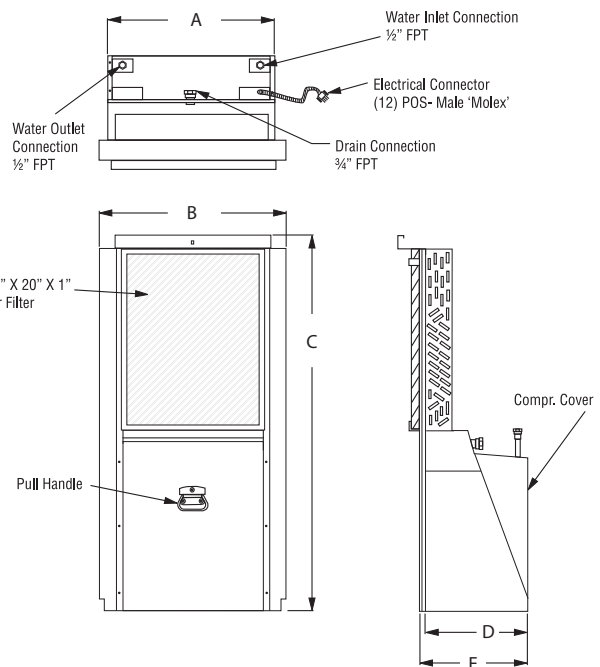

Rome, New York 13440

Phone (315) 339-2331 • Fax (315) 339-2358

[www.ColdPointCorp.com](http://www.ColdPointCorp.com)

©2017 Cold Point Corp. All rights reserved.



CPL038 rev. 08-17