

ADIRONDACK AIR

Series ACW

American Air Filter SSACW Series

Application Flexible | Fast and Easy Replacement | Damage Protection

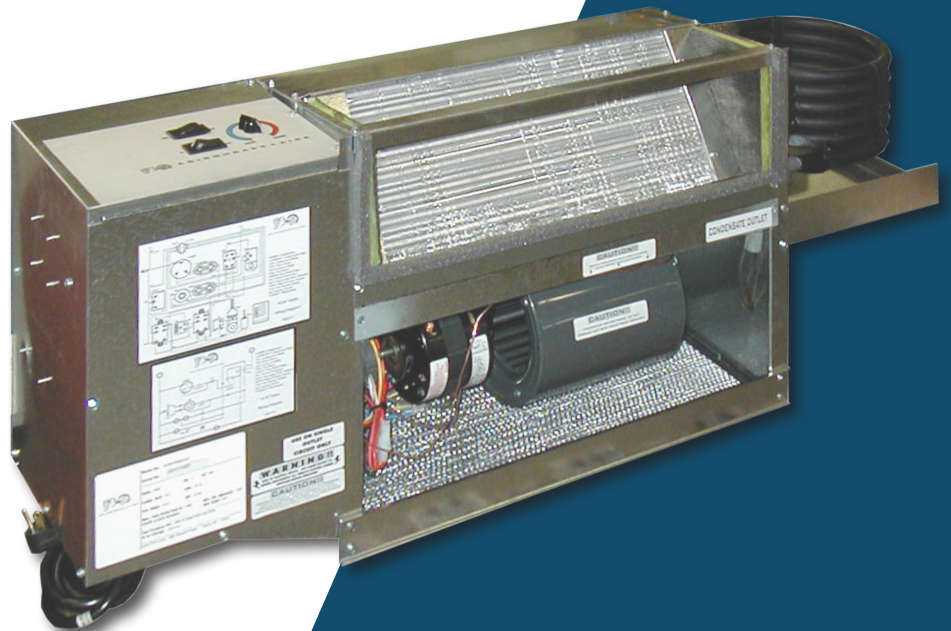

ADIRONDACK-AIRE ACW CHASSIS SERIES

Replaces American Air Filter SSACW

The Adirondack-Aire ACW series zerOzone replacement console units provide environment friendly, high efficiency, cooling and heating where individual, quiet control is a priority. This application flexible unit is also a direct replacement for American Air Filter SSACW series console water source heat pump units. These console units are offered as chassis only to work with the existing or custom cabinets and also offered with cabinets for a complete upgrade. The chassis contains the compressor, air side heat exchanger, water side heat exchanger, evaporator fan and motor, control components and safety components. The optional room cabinet is powder painted furniture-grade steel construction with extruded aluminum grille and control door.

The chassis is dimensionally identical to the original for a fast, easy, and trouble-free installation. Quality components, careful design and testing and the latest in environment friendly technology advances mean long unit life, user satisfaction and lower energy costs. Consider the extensive list of standard features, which includes: powder painted drain pan, refrigerant circuit filter-drier, electrostatic air filter, evaporator freeze protection, water coil freezestat, high-pressure over protection, and electronic control board. Adirondack-Aire is the replacement solution that the competition can't match. Cold Point Corp. backs the ACW with a customer friendly one-year parts and labor warranty and five-year compressor warranty, (see Warranty document for details).

Standard Features:

- Made in the USA
- Designed for easy installation and compatibility. Dimensionally identical to original American Air Filter SSACW chassis
- ETL approved
- Quiet, durable, and efficient compressor with built-in pressure and temperature protection
- Heavy gauge G90 galvanized steel construction
- Powder-painted drain pan
- High efficiency copper tube-aluminum fin evaporator coil
- High efficiency coaxial condenser coil with low water-side pressure drop
- Unit-mounted digital controls
- Electronic control board with anti-short cycle protection
- High pressure switch
- Frost-free cooling
- Water coil freeze protection
- Refrigerant circuit access ports
- Capillary expansion
- Positive shift reversing valve
- Precision charged with zerOzone R-410A refrigerant
- 1/2 Inch water connections
- Electrostatic air filter

Electrical Data

Model	Compressor Type	Voltage Volt-Hz-Ph	Fan		Compressor		Total Amps	Ckt Amps	Max Fuse	Min Volts
			Amps	HP	RLA	LRA				
ACW-08	Rotary	115/60/1	1.20	1/10	6.1	39.1	7.3	8.0	15	104
ACW-08	Rotary	208-230/60/1	0.40	1/10	3	15	3.4	5.0	15	197
ACW-08	Rotary	265/60/1	0.35	1/10	2.7	11	3.1	4.0	15	240
ACW-10	Rotary	115/60/1	1.20	1/10	8.0	50.0	9.2	12.0	15	104
ACW-10	Rotary	208-230/60/1	0.40	1/10	3.7	22.0	4.1	6.0	15	197
ACW-10	Rotary	265/60/1	0.40	1/10	3.5	22.0	3.9	5.0	15	240
ACW-12	Rotary	115/60/1	1.20	1/10	9.5	50.0	10.7	13.0	20	104
ACW-12	Rotary	208-230/60/1	0.40	1/10	4.70	25.0	5.1	7.0	15	197
ACW-12	Rotary	265/60/1	0.40	1/10	4.2	22.0	4.6	6.0	15	240
ACW-15	Rotary	208-230/60/1	0.60	1/10	5.6	29.0	6.2	8.0	15	197
ACW-15	Rotary	265/60/1	0.60	1/10	5.0	28.0	5.6	7.0	15	240
ACW-19	Rotary	208-230/60/1	0.60	1/10	7.4	33.0	8.0	10.0	15	197
ACW-19	Rotary	265/60/1	0.60	1/10	6.0	28.0	6.6	9.0	15	240



ACW CHASSIS APPLICATION & BENEFITS

Fast and Easy Replacement

The Adirondack-Aire ACW series zerOzone replacement chassis fits the existing American Air Filter room cabinets without modification. Because the ACW dimensions and construction details are like the original, replacement work is fast and easy. Water, drain and electrical connections line right up to the existing connections. Using Adirondack-Aire replacements eliminates the need for room renovation, redecorating, or piping and wiring changes. The ACW is the solution that gets your property back in service quickly and at the lowest total cost. Choose

the optional room cabinet to give the unit a new look and improve room aesthetics.

Damage Protection

The standard high-pressure switch, evaporator coil freeze protection, and electronic control board stop unit operation before damage occurs, should airflow become reduced or obstructed due to dirty coils, obstructed airflow, or motor failure. A freezestat protects the water coil from freeze damage due to water temperature or flow problems. The water coil is designed for low water-side pressure drop, eliminating potential pump sizing and water flow problems.

Options and Accessories

- Room cabinet
- Fresh air sub-base
- Control options
- 115V and 265/277V (Availability varies by model size)
- Flow control valve
- Valves and unions
- Hose kits
- Line cords

Performance Ratings

Model	Cool Btuh	Sens Btuh	EER	Heat Btuh	COP	CFM Hi/Lo	GPM	Coil PD	Refrigerant
ACW-08	7,900	6,000	14.4	9,500	4.6	300/270	2.0	1.2'	R-410AS
ACW-10	9,700	7,800	13.5	10,500	4.2	390/300	2.5	1.8'	R-410A
ACW-12	12,700	10,000	13.2	13,200	4.2	435/345	2.5	1.8'	R-410A
ACW-15	Consult Factory								R-410A
ACW-19	Consult Factory								R-410A

Continuous engineering improvements may result in performance changes without notice.

NEMA Configurations

Non Locking Plugs/Receptacles

Voltage	125V	250V	277V
15A Recp.	5-15R 	6-15R 	7-15R
15A Plug	5-15P 	6-15P 	7-15P
20A Recp.	5-20R 	6-20R 	7-20R
20A Plug	5-20P 	6-20P 	7-20P
30A Recp.	5-30R 	6-30R 	7-30R
30A Plug	5-30P 	6-30P 	7-30P

277V Line cord N/A as factory installed

Unit Sizes

Model	Chassis Weight (lbs)
ACW-08	150
ACW-10	150
ACW-12	150
ACW-15	175
ACW-19	175

Chassis Sizes 08 and 10

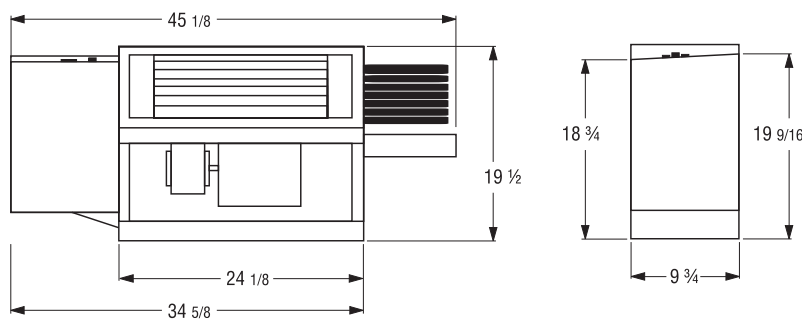

Chassis Size 12

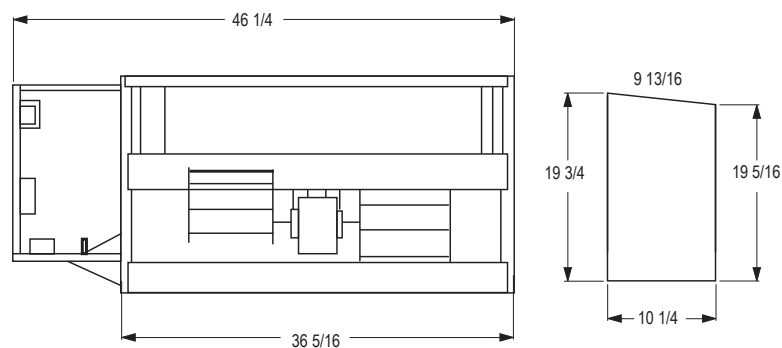

Optional Room Cabinet with Sub-Base

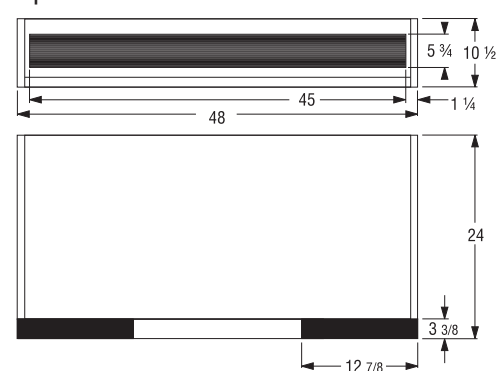

Size 08 and 10 only. Consult factory for 12, 15 and 19 dimensions.

INNOVATIVE HEATING AND COOLING SOLUTIONS

Cold Point equipment has been specified in hundreds of projects in these and other applications:
Direct Replacement | New Construction | Renovation | Commercial & Residential Solutions

Cold Point values reliability as much as you

Your Cold Point sales representative knows their reputation is on the line with every sale. Therefore, they are as personally invested in your comfort as you are, and take great pride in creating your perfect indoor environment.

Rest comfortably, knowing Cold Point stands behind our products

The Cold Point Corporation backs our products with a standard warranty that includes labor for the entire first year of ownership. Registered Limited Warranty terms include: 12 month limited warranty on components, 60 month limited warranty on all unit compressors from the date of original installation OR 15 months limited warranty on components, 63 month limited warranty on all unit compressors from the date of original sale, whichever comes first. For all coverage options and complete coverage terms, check with your local Cold Point representative for full details.

Industry-leading expertise

Cold Point Corporation is the industry-leading supplier of aftermarket comfort solutions for commercial and residential applications. We have over 18 years of experience developing OEM-style replacement products to keep you happy and comfortable. Whether it is a water source heat pump application or an air source PTAC system, Cold Point has the knowledge and products to restore your system to its original operating condition.

Reliable comfort products backed by the industry experts in OEM-style replacement units

To learn more about how the Cold Point Corporation can help you save time and money on your next project, contact your local Cold Point representative. Call **315-339-2331** to speak with one of our specialists, or e-mail your request to info@coldpointcorp.com.

Your Cold Point Representative:



510 Henry Street • Rome, New York 13440
Phone (315) 339-2331 • Fax (315) 339-2358
www.ColdPointCorp.com

©2023 Cold Point Corp. All rights reserved.



rev. 09-23 CPL015