

ADIRONDACK ▲ AIRE

Series WPV

Command-Aire WPV Series, Trane WPR Series

Application Flexible | Fast and Easy Replacement | Damage Protection



ADIRONDACK-AIRE WPV CHASSIS SERIES

Replaces Command-Aire WPV Series and Trane WPR Series

The Adirondack-Aire WPV Series zerOzone replacement chassis provides environment friendly, high efficiency cooling and heating where individual, quiet control is a priority. This application flexible unit is also a direct replacement* for Command-Aire WPV and Trane WPR series vertical stacked water source heat pump chassis. The chassis is a part of a complete system, which consists of the chassis, blower section, control box, and furred-in room cabinet with risers. The chassis contains the compressor, air side heat exchanger, water side heat exchanger, and refrigerant circuit control and safety components.

The WPV is dimensionally identical to the original for a fast, easy, and trouble-free installation. Quality components, careful design and testing and the latest in environment friendly technology mean long unit life, user satisfaction, and lower energy costs. Consider the extensive list of standard features which includes: powder painted drain pan, refrigerant circuit access ports, pull handle, compressor protected suction accumulator, evaporator freeze protection, water coil freeze stat, high-pressure over protection, and lockout circuit**. Adirondack-Aire is the replacement solution for upgrading old, worn out, inefficient original chassis. Cold Point Corp. backs the WPV with a customer friendly one-year parts and labor warranty and five-year compressor warranty, (see Warranty document for details).

*Various wiring configurations were produced. See specs and price sheet for details.

** Model specific. May include lockout circuit, five minute anti-short cycle timer or interconnect control utilizing control panel logics.

Standard Features:

- Made in the USA
- Designed for easy installation and compatibility. Dimensionally identical to original Command-Aire and Trane chassis
- ETL safety labeled
- Quiet, durable, and efficient compressor with built-in pressure and temperature protection
- Heavy gauge G90 galvanized steel construction
- Powder-painted or stainless steel drain pan
- High efficiency copper tube-aluminum fin evaporator coil
- High efficiency coaxial condenser coil with low water-side pressure drop
- Lock out circuit** with reset or circuit breaker
- High pressure switch
- Frost-free cooling
- Water coil freeze protection
- Refrigerant circuit access ports
- Precision selected capillary tube refrigerant control
- Positive shift reversing valve
- Precision charged with zerOzone R-410A refrigerant
- 1/2 Inch FPT connections
- Chassis pull handle facilitates easy chassis removal and handling

Electrical Data

Model	Compressor Type	Voltage Volt-Hz-Ph	RLA	LRA	Total Amps	Ckt Amps	Max Fuse	Min Volts
WPV-10	Rotary	208/230/60/1	3.7	22.0	3.7	5.0	15	197
WPV-10	Rotary	265/60/1	3.5	22.0	3.5	5.0	15	240
WPV-12	Rotary	208/230/60/1	4.7	25.0	4.7	6.0	15	197
WPV-12	Rotary	265/60/1	4.2	22.0	4.2	6.0	15	240
WPV-20	Rotary	208/230/60/1	7.4	33.0	7.4	10.0	15	197
WPV-20	Rotary	265/60/1	6.0	28.0	6.0	8.0	15	240
WPV-26	Recip	208/230/60/1	7.4	43.0	7.4	10.0	15	197
WPV-26	Recip	265/60/1	6.7	46.0	6.7	9.0	15	240
WPV-33	Recip	208/230/60/1	11.6	74.0	11.6	15.0	25	197
WPV-33	Recip	265/60/1	9.9	67.0	9.9	13.0	20	240



WPV CHASSIS APPLICATION & BENEFITS

Fast and Easy Replacement

The Adirondack-Aire WPV series replacement chassis fits the existing Command-Aire and Trane room cabinets and works with the existing blower section and control box without modification. Because the chassis dimensions and construction details are like the original, replacement work is fast and easy. The chassis installs without the need for water loop shut-down or draining. Water, drain and electrical connections line right up to the original installation. The electrical connectors plug directly into the control box connectors. A chassis pull handle is provided to facilitate easy removal and handling. Using Adirondack-Aire

replacements eliminates the need for room renovation, redecorating, and piping changes and is the solution that gets your property back in service quickly and at the lowest total cost.

Damage Protection

The standard high-pressure switch and evaporator coil freeze protection stop unit operation before damage occurs should airflow become reduced or obstructed due to dirty coils, obstructed airflow, or motor failures or lock-up. A freezestat protects the water coil from freeze damage due to water temperature or flow problems. The water coil is designed for low water-side pressure drop eliminating potential pump sizing and water flow problems.

Options and Accessories

- Blower sections
- Return air panels
- Control options
- 115V, 265V/277V (Availability varies by model sizes)
- Flow control valve
- Hose kits

Performance Ratings

Model	Cool* Btuh	Sens Btuh	EER*	Heat* Btuh	COP*	CFM (Design)	GPM	Coil PD	Refrigerant
WPV-10	9,900	7,700	14.3	12,000	4.7	360	2.5	1.8'	R-410A
WPV-12	12,500	8,800	13.9	14,900	4.4	400	3.0	2.5'	R-410A
WPV-20	18,900	14,300	13.1	25,600	4.7	640	5.0	3.9'	R-410A
WPV-26	25,900	20,700	14.5	28,900	4.4	800	6.5	7.4'	R-410A
WPV-33	36,400	26,600	14.5	42,600	4.4	1100	8.3	3.3'	R-410A

Continuous engineering improvements may result in performance changes without notice.

* Includes 1250Btu/1000 CFM fan heat and 365w/1000 CFM fan power. Fan power and pumping corrections are not included for rating purposes. 208v data shown. 115v & 265v ratings may vary.

Unit Sizes

Model	A	B	C	D	E	F	G	Shipping Weight (lbs)
	Inches							
WPV-10	13 1/2	12 1/2	32 5/8	14 1/2	14 3/8	17 7/8	N/A	69
WPV-12	13 1/2	12 1/2	32 5/8	14 1/2	14 3/8	17 7/8	N/A	70
WPV-20	17 1/2	15 1/4	33 5/8	16 5/8	15 3/8	N/A	17 7/8	87
WPV-26	17 3/4	15 1/4	34 1/2	16 5/8	15 3/8	N/A	17 7/8	129
WPV-33	21 7/16	19	38 3/8	16 5/8	16 3/32	19 5/8	N/A	152

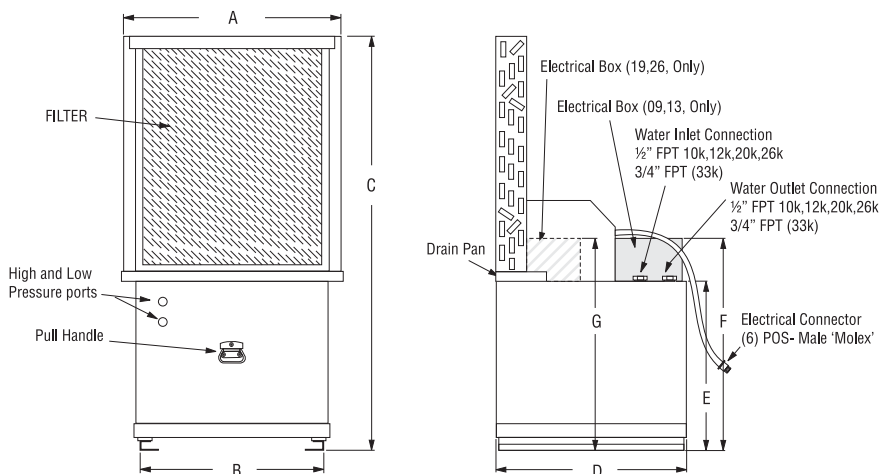

INNOVATIVE HEATING AND COOLING SOLUTIONS

Cold Point equipment has been specified in hundreds of projects in these and other applications:
Direct Replacement | New Construction | Renovation | Commercial & Residential Solutions

Cold Point values reliability as much as you

Your Cold Point sales representative knows their reputation is on the line with every sale. Therefore, they are as personally invested in your comfort as you are, and take great pride in creating your perfect indoor environment.

Rest comfortably, knowing Cold Point stands behind our products

The Cold Point Corporation backs our products with a standard warranty that includes labor for the entire first year of ownership. Registered Limited Warranty terms include: 12 month limited warranty on components, 60 month limited warranty on all unit compressors from the date of original installation OR 15 months limited warranty on components, 63 month limited warranty on all unit compressors from the date of original sale, whichever comes first. For all coverage options and complete coverage terms, check with your local Cold Point representative for full details.

Industry-leading expertise

Cold Point Corporation is the industry-leading supplier of aftermarket comfort solutions for commercial and residential applications. We have over 18 years of experience developing OEM-style replacement products to keep you happy and comfortable. Whether it is a water source heat pump application or an air source PTAC system, Cold Point has the knowledge and products to restore your system to its original operating condition.

Reliable comfort products backed by the industry experts in OEM-style replacement units

To learn more about how the Cold Point Corporation can help you save time and money on your next project, contact your local Cold Point representative. Call **315-339-2331** to speak with one of our specialists, or e-mail your request to info@coldpointcorp.com.

Your Cold Point Representative:



510 Henry Street • Rome, New York 13440
Phone (315) 339-2331 • Fax (315) 339-2358
www.ColdPointCorp.com

©2023 Cold Point Corp. All rights reserved.



rev. 09-23 CPL009