

ADIRONDACK ▲ AIRE

## Series HCC

### Singer / McQuay HCC Series

Application Flexible | Fast and Easy Replacement | Damage Protection



# ADIRONDACK-AIRE HCC CHASSIS SERIES

## Replaces Singer/McQuay HCC Series

The Adirondack-Aire HCC series zerOzone replacement chassis provides environment friendly, high efficiency cooling and heating where individual, quiet control is a priority. This application flexible unit is a direct replacement for Singer/McQuay HCC series vertical stacked water source heat pump chassis. The chassis is a part of a complete system, which consists of the chassis, blower section, control box, and furred-in room cabinet with risers. The chassis contains the compressor, air side heat exchanger, water side heat exchanger, Jones plug, and control panel and safety components.

The HCC series has two chassis sizes, small (models 090 and 120), and large (models 180 and 240). Both chassis sizes are dimensionally identical to the original for a fast, easy, and trouble-free installation. Quality components, careful design and testing and the latest in environment friendly technology mean long unit life, user satisfaction, and lower energy costs. Consider the extensive list of standard features which includes: powder painted drain pan, refrigerant circuit access ports, air filter, pull handle, compressor protected suction accumulator, evaporator freeze protection, water coil freezestat, high-pressure over protection, and lock out circuit\*. Adirondack-Aire is the replacement solution for upgrading old, worn out, inefficient original chassis. Cold Point Corp. backs the HCC with a customer friendly one-year parts and labor warranty and five-year compressor warranty, (see Warranty document for details).

\* Model specific. May include lock out circuit, five minute anti-short cycle timer or interconnect control utilizing control panel logics.

### Standard Features:

- Made in the USA
- Designed for easy installation and compatibility. Dimensionally identical to original Singer/McQuay chassis
- ETL safety labeled
- Quiet, durable, and efficient compressor with built-in pressure and temperature protection
- Heavy gauge G90 galvanized steel construction
- Powder painted drain pan
- High efficiency copper tube-aluminum fin evaporator coil
- High efficiency coaxial condenser coil with low water-side pressure drop
- Lock out circuit\* with reset at thermostat or circuit breaker
- Jones plug electrical connector
- High pressure switch
- Frost-free cooling
- Water coil freeze protection
- Refrigerant circuit access ports
- Precision selected capillary tube refrigerant control
- Positive shift reversing valve
- Precision charged with zerOzone R-410A refrigerant
- 1/2 Inch FPT water connections
- Chassis pull handle facilitates easy chassis removal and handling
- 1 Inch Fiberglass or natural fiber air filter

### Electrical Data

Model	Compressor Type	Voltage Volt-Hz-Ph	RLA	LRA	Total Amps	Ckt Amps	Max Fuse	Min Volts
HCC-10	Rotary	208/230/60/1	3.7	22.0	3.7	5.0	15	197
HCC-10	Rotary	265/60/1	3.5	22.0	3.5	5.0	15	240
HCC-12	Rotary	208/230/60/1	4.7	25.0	4.7	6.0	15	197
HCC-12	Rotary	265/60/1	4.2	22.0	4.2	6.0	15	240
HCC-20	Rotary	208/230/60/1	7.4	33.0	7.4	6.0	15	197
HCC-20	Rotary	265/60/1	6.0	28.0	6.0	8.0	15	240
HCC-24	Recip.	208/230/60/1	7.4	43.0	7.4	10.0	15	197
HCC-24	Recip.	265/60/1	6.7	46.0	6.7	8.0	15	240



# HCC CHASSIS APPLICATION & BENEFITS

## Fast and Easy Replacement

The Adirondack-Aire HCC series zerOzone replacement chassis fits the existing Singer/McQuay room cabinets and works with the existing blower section and control box without modification. Because the chassis dimensions and construction details are like the original, replacement work is fast and easy. The chassis installs without the need for water loop shut-down or draining. Water, drain and electrical connections line right up to the original installation. The electrical connectors plug directly into the control box connectors. A chassis pull handle is provided to facilitate easy removal and handling. Using Adirondack-Aire replacements eliminates

the need for room renovation, redecorating, and piping changes and is the solution that gets your property back in service quickly and at the lowest total cost.

## Damage Protection

The standard high-pressure switch and evaporator coil freeze protection stop unit operation before damage occurs, should airflow become reduced or obstructed due to dirty coils, obstructed airflow, or motor failure or lock up. A freestat protects the water coil from freeze damage due to water temperature or flow problems. The water coil is designed for low water-side pressure drop, eliminating potential pump sizing and water flow problems.

## Options and Accessories

- Blower sections
- Return air panels
- Control options
- 115V, 265V/277V (Availability varies by model sizes)
- Flow control valve
- Hose kits

## Performance Ratings

Model	Cool* Btuh	Sens Btuh	EER*	Heat* Btuh	COP*	CFM Hi/Low	GPM	Coil PD	Refrigerant
HCC-10	9,900	7,600	13.3	11,700	4.37	300	2.5	1.8'	R-410A
HCC-12	11,800	8,600	13.5	13,100	4.20	350/300	3.0	2.5'	R-410A
HCC-20	18,500	13,250	13.8	21,950	4.50	580/430	5.0	4.0'	R-410A
HCC-24	23,000	17,000	13.6	27,000	4.40	830/680	6.0	6.5'	R-410A

Continuous engineering improvements may result in performance changes without notice.

\* Includes 1250Btu/1000 CFM fan heat and 365w/1000 CFM fan power. Fan power and pumping corrections are not included for rating purposes. 208v data shown. 115v and 265v ratings may vary.

## Unit Sizes

Model	A	B	C	D	E	F	Filter Size	Chassis Weight (lbs)
	Inches							
HCC-10	13 3/4	2 3/4	39	15 1/4	14 3/4	14 1/4	14 x 16 x 1	76
HCC-12	13 3/4	2 3/4	39	15 1/4	14 3/4	14 1/4	14 x 16 x 1	120
HCC-20	16 1/2	3	39	18 1/4	17 5/8	17 1/8	17 x 18 x 1	145
HCC-24	16 1/2	3	39	18 1/4	17 5/8	17 1/8	17 x 18 x 1	160

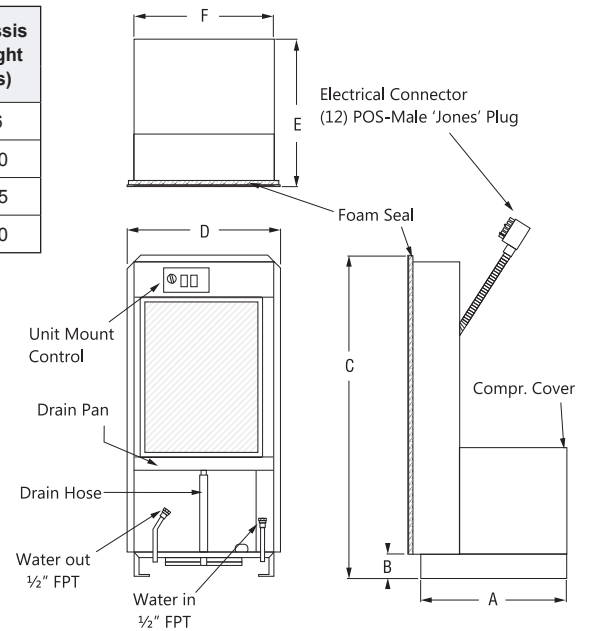

# INNOVATIVE HEATING AND COOLING SOLUTIONS

Cold Point equipment has been specified in hundreds of projects in these and other applications:  
Direct Replacement | New Construction | Renovation | Commercial & Residential Solutions

## Cold Point values reliability as much as you

Your Cold Point sales representative knows their reputation is on the line with every sale. Therefore, they are as personally invested in your comfort as you are, and take great pride in creating your perfect indoor environment.

## Rest comfortably, knowing Cold Point stands behind our products

The Cold Point Corporation backs our products with a standard warranty that includes labor for the entire first year of ownership. Registered Limited Warranty terms include: 12 month limited warranty on components, 60 month limited warranty on all unit compressors from the date of original installation OR 15 months limited warranty on components, 63 month limited warranty on all unit compressors from the date of original sale, whichever comes first. For all coverage options and complete coverage terms, check with your local Cold Point representative for full details.

## Industry-leading expertise

Cold Point Corporation is the industry-leading supplier of aftermarket comfort solutions for commercial and residential applications. We have over 18 years of experience developing OEM-style replacement products to keep you happy and comfortable. Whether it is a water source heat pump application or an air source PTAC system, Cold Point has the knowledge and products to restore your system to its original operating condition.

## Reliable comfort products backed by the industry experts in OEM-style replacement units

To learn more about how the Cold Point Corporation can help you save time and money on your next project, contact your local Cold Point representative. Call **315-339-2331** to speak with one of our specialists, or e-mail your request to [info@coldpointcorp.com](mailto:info@coldpointcorp.com).

Your Cold Point Representative:



510 Henry Street • Rome, New York 13440  
Phone (315) 339-2331 • Fax (315) 339-2358  
[www.ColdPointCorp.com](http://www.ColdPointCorp.com)

©2023 Cold Point Corp. All rights reserved.



rev. 09-23 CPL006