



PWC Series

PTAC Replacement Chassis

INSTALLATION, OPERATION & MAINTENANCE MANUAL



Attentions, Cautions, and Warnings



Safety

Warnings, cautions, and notices are present throughout this manual. Read this information carefully before performing any installation, service, or troubleshooting of the equipment.

WARNING: Indicates a potentially hazardous situation, which if not avoided could result in death or serious injury.

CAUTION: Indicates a potentially hazardous situation or an unsafe practice, which if not avoided could result in minor or moderate injury or product or property damage.

NOTICE: Notification of installation, operation, or maintenance information, which is important, but which is not hazard-related

 WARNING	
	Disconnect power supply(ies) before servicing. Refer servicing to qualified service personnel. Electric shock hazard. May result in injury or death!

 WARNING	
To avoid the release of refrigerant into the atmosphere, the refrigerant circuit of this unit must be serviced only by technicians who meet local, state, and federal proficiency requirements.	

 WARNING	
The installation of water-source heat pumps and all associated components, parts, and accessories which make up the installation shall be in accordance with the regulations of ALL authorities having jurisdiction and MUST conform to all applicable codes. It is the responsibility of the installing contractor to determine and comply with ALL applicable codes and regulations.	

 WARNING	
The appliance shall be stored in a room without continuously operating ignition sources (for example: open flames, an operating gas appliance or an operating electric heater).	

 WARNING	
Be aware that refrigerants may not contain odor.	

 WARNING	
If unit connected via an air duct system to one or more rooms with R-454B is installed in a room with an area less than Amin or has an Effective Dispersal Volume less than minimum, that room shall be without continuously operating open flames or other POTENTIAL IGNITION SOURCES . A flame-producing device may be installed in the same space if the device is provided with an effective flame arrest.	

 WARNING	
All refrigerant discharged from this unit must be recovered WITHOUT EXCEPTION . Technicians must follow industry accepted guidelines and all local, state, and federal statutes for the recovery and disposal of refrigerants. If a compressor is removed from this unit, refrigerant circuit oil will remain in the compressor. To avoid leakage of compressor oil, refrigerant lines of the compressor must be sealed after it is removed.	

 WARNING	
This appliance is not intended for use by persons (including children) with reduced physical, sensory, or mental capabilities, or lack of experience and knowledge, unless they have been given supervision or instruction concerning use of the appliance by a person responsible for their safety.	

 WARNING	
An unventilated area where the appliance using FLAMMABLE REFRIGERANTS is installed shall be so constructed that should any refrigerant leak, it will not stagnate so as to create a fire or explosion hazard.	

 WARNING	
Only auxiliary electric heaters approved by Cold Point shall be installed in connecting ductwork. The installation of any other auxiliary devices is beyond Cold Point's responsibility.	

 WARNING	
Children being supervised are NOT to play with the appliance.	

 WARNING	
Do not pierce or burn.	

 WARNING	
Do not use means to accelerate the defrosting process or to clean, other than those recommended by the manufacturer.	

 WARNING	
Sealed electrical components shall be replaced.	

Attentions, Cautions, and Warnings

CAUTION

DO NOT store or install units in corrosive environments or in locations subject to temperature or humidity extremes (e.g., attics, garages, rooftops, etc.). Corrosive conditions and high temperature or humidity can significantly reduce performance, reliability, and service life. Always move and store units in an upright position. Tilting units on their sides will cause equipment damage.

CAUTION

CUT HAZARD - Failure to follow this caution may result in personal injury. Sheet metal parts may have sharp edges or burrs. Use care and wear appropriate protective clothing, safety glasses and gloves when handling parts and servicing air conditioners and heat pumps.

CAUTION

To avoid equipment damage, DO NOT use these units as a source of heating or cooling during the construction process. The mechanical components and filters can quickly become clogged with construction dirt and debris, which may cause system damage and void product warranty.

CAUTION

All three phase scroll compressors must have direction of rotation verified at startup. Verification is achieved by checking compressor Amp draw. Amp draw will be substantially lower compared to nameplate values. Additionally, reverse rotation results in an elevated sound level compared to correct rotation. Reverse rotation will result in compressor internal overload trip within several minutes. Verify compressor type before proceeding.

CAUTION

Units with a factory SUPPLY CORD and a plug, or with the optional unit disconnect, provides full disconnection under overvoltage from the supply mains. Where factory disconnect is NOT provided, the means for disconnection must be incorporated in the fixed wiring in accordance with the wiring rules and local codes.

CAUTION

Non-duct connected appliances containing A2L refrigerants with the supply and return air openings in the conditional space may have the body of the appliance may be installed in open areas such as false ceilings not being used as return air plenums, as long as the conditioned air does not directly communicate with the air of the false ceiling.

CAUTION

For duct connected appliances containing A2L refrigerants, false ceilings or drop ceilings may be used as a return air plenum if a REFRIGERANT DETECTION SYSTEM is provided in the appliance and any external connections are also provided with a sensor immediately below the return air plenum duct joint.

NOTICE

Servicing shall be performed only as recommended by the manufacturer.

NOTICE

For Installation Only in Locations Not Accessible to the General Public

General Information

Inspection:

Upon receiving your equipment, carefully check the shipment against the bill of lading. Make sure you have received all units. Inspect each unit and its packaging for any damage. **Ensure that the carrier completes a common carrier inspection report, noting any shortages or damages on all copies of the freight bill. Any concealed damage not previously noted must be reported to the carrier within 10 days of receipt of shipment. The freight company can deny the claim without recourse if not filed within 10 days.**

NOTE: It is the responsibility of the purchaser to file all damage claims with the carrier within 10 days of shipment.

Storage:

Equipment should be stored in its original packaging in a clean, dry location. Units should be in an upright position at all times. Units may be stacked a maximum of three units high.

Unit Protection:

Units on a job site should be covered with either the original packaging or an equivalent covering. Cap all open ends of pipes stored on the job site. In locations where painting, plastering, or spraying remains unfinished, it is essential to implement all required measures to prevent physical damage to the units and to avoid contamination from external materials. Such damage and contamination can hinder proper system startup and lead to expensive cleaning of the equipment.

Prior to the installation of any system components, it is important to inspect all pipes, fittings, and valves. Ensure that any dirt or debris present on or within these components is removed.

Pre-installation:

Each unit has instructions for installation, operation, and maintenance. It is essential to select an installation site that allows for sufficient service clearance around the unit. Prior to starting the unit, it is important to review all manuals and familiarize yourself with the unit's functions. Additionally, perform a thorough system check before commencing operation.

Preparation of Units for Installation:

1. Verify Unit Shipment: Confirm that the electrical specifications on the unit's nameplate match the ordering and shipping documentation to ensure the correct unit has been delivered.

2. Protect the Cabinet: Maintain the cabinet's protection by keeping it covered with the original packaging until the installation is finalized and all related tasks.

3. Check Refrigerant Tubing: Ensure that the refrigerant tubing is free from kinks or dents and that it does not come into contact with other components of the unit.

4. Examine Electrical Connections: Inspect all electrical connections to ensure they are clean and securely fastened at the terminals.

5. Locate Accessories: Identify and confirm the presence of any accessory kits that were factory installed as ordered.

Safety Checks:

Before commencing any work on systems that utilize FLAMMABLE REFRIGERANTS, it is essential to conduct safety checks to reduce the potential for ignition. These precautions must be taken prior to any repairs on the REFRIGERATING SYSTEM.

Work Procedure:

Tasks will be executed following a regulated process to reduce the likelihood of flammable gases or vapors being present during the execution of the work.

General Work Area:

All maintenance personnel and those present in the vicinity must be informed about the nature of the activities being performed. Work within confined spaces should be avoided whenever possible.

Checking for Presence of Refrigerant:

Prior to and throughout the duration of the work, the area must be examined with a suitable refrigerant detector to ensure that technicians are aware of any potentially toxic or flammable environments. It is essential that the leak detection equipment used is appropriate for all relevant refrigerants, meaning it should be non-sparking, properly sealed, or

General Information

intrinsically safe.

Presence of Fire Extinguisher:

In the event that hot work is to be performed on refrigeration equipment or related components, appropriate fire extinguishing devices must be readily accessible. A dry powder or CO2 fire extinguisher should be located near the charging area.

No Ignition Sources:

Individuals involved in work related to a REFRIGERATION SYSTEM that necessitates exposing any piping must refrain from using any ignition sources that could pose a fire or explosion risk. All potential ignition sources, such as smoking, should be kept at a safe distance from areas of installation, repair, removal, or disposal where refrigerant may be released into the environment. Before commencing work, a thorough assessment of the area surrounding the equipment must be conducted to ensure there are no flammable hazards or ignition risks. "No Smoking" signs should be prominently displayed.

Ventilated Area:

Ensure that the work area is either outdoors or sufficiently ventilated prior to breaking into the system or performing any hot work. Ventilation should be maintained throughout the duration of the work to safely disperse any released refrigerant and, if possible, vent it externally into the atmosphere.

Checks to the Refrigeration Equipment:

The following checks shall be applied to installations using FLAMMABLE REFRIGERANTS:

- The actual REFRIGERANT CHARGE is in accordance with the room size within which the refrigerant containing parts are installed;
- The ventilation machinery and outlets are operating adequately and are not obstructed;
- If an indirect refrigerating circuit is being used, the secondary circuit shall be checked for the presence of refrigerant;
- Marking to the equipment continues to be visible and legible. Markings and signs that are illegible shall be corrected;

- Refrigerant piping or components are installed in a position where they are unlikely to be exposed to any substance which may corrode refrigerant containing components, unless the components are constructed of materials which are inherently resistant to being corroded or are suitably protected against being so corroded.

Checks to Electrical Devices:

Repair and maintenance to electrical components shall include initial safety checks and component inspection procedures. If a fault exists that could compromise safety, then no electrical supply shall be connected to the circuit until it is satisfactorily dealt with. If the fault cannot be corrected immediately but it is necessary to continue operation, an adequate temporary solution shall be used. This shall be reported to the owner of the equipment so all parties are advised.

Initial safety checks shall include:

- Capacitors are discharged: this shall be done in a safe manner to avoid possibility of sparking;
- That no live electrical components and wiring are exposed while charging, recovering, or purging the system;
- That there is continuity of earth bonding.

General Information

Repair to intrinsically safe components:

Intrinsically safe components must be replaced.

Cabling:

Ensure that the cabling is protected from wear, corrosion, excessive pressure, vibrations, sharp edges, and any other detrimental environmental factors. This assessment should also consider the impacts of aging and ongoing vibrations from equipment such as compressors or fans.

Required Area For Installation:

The minimum area of the installation space (A_{min}) or the minimum area of the conditioned space (T_{amin}) must be adjusted based on the unit's altitude. This adjustment is done by multiplying A_{min} or T_{amin} by the relevant altitude adjustment factor (AF) corresponding to the building's ground-level altitude (H_{alt}) in either feet or meters, as detailed in Table 1.

Note: You can use Imperial or Metric measurements to calculate A_{min} or T_{amin} .

Table 1: Altitude Adjustment

Halt ft (m)	AF
0 (0)	1.00
656 (200)	1.00
1,312 (400)	1.00
1,968 (600)	1.00
2,624 (800)	1.02
3,280 (1,000)	1.05
3,937 (1,200)	1.07
4,593 (1,400)	1.10
5,249 (1,600)	1.12
5,905 (1,800)	1.15
6,561 (2,000)	1.18
7,217 (2,200)	1.21
7,874 (2,400)	1.25
8,530 (2,600)	1.28
9,186 (2,800)	1.32
9,842 (3,000)	1.36
10,498 (3,200)	1.40

Refrigerant System Servicing

Refrigerant System

To ensure the integrity of the sealed circuit, avoid installing service gauges unless the unit's performance is abnormal. Before servicing the refrigerant circuit, confirm that the air and water flow rates are within acceptable limits.

Removal and Evacuation:

When accessing the refrigerant circuit for repairs or other purposes, standard procedures should be followed. However, for flammable refrigerants, it is crucial to adhere to best practices due to the associated flammability risks. The following protocol must be observed:

- Safely extract the refrigerant in accordance with local and national regulations.

- Evacuate the system.
- Purge the circuit with inert gas.
- Evacuate again.
- Continuously flush or purge with inert gas while using flame to open the circuit.
- Open the circuit.

Refrigerant should be recovered into the appropriate recovery cylinders if venting is prohibited by local and national regulations. For appliances utilizing flammable refrigerants, the system must be purged with oxygen-free nitrogen to ensure safety. This purging process may require repetition. It is important

Refrigerant System Servicing

to avoid using compressed air or oxygen for purging refrigerant systems.

For appliances with flammable refrigerants, the purging process involves breaking the vacuum with oxygen-free nitrogen, filling until the desired working pressure is reached, venting to the atmosphere, and then optionally pulling down to a vacuum. This procedure should be repeated until no refrigerant remains in the system (optional for FLAMMABLE REFRIGERANTS). After the final oxygen-free nitrogen charge, the system should be vented to atmospheric pressure to facilitate work. Ensure that the outlet for the vacuum pump is positioned away from any potential ignition sources and that adequate ventilation is provided.

Charging Procedures:

Before recharging the system, it must be pressure-tested using the appropriate purging gas. In addition to standard charging protocols, the following guidelines must be observed:

- Prevent contamination of different refrigerants when using charging equipment.
- Keep hoses or lines as short as possible to limit the amount of refrigerant they contain.
- Maintain cylinders in the correct position according to provided instructions.
- Verify that the refrigeration system is properly grounded before charging with refrigerant.
- Label the system upon completion of charging (if not already labeled).
- Exercise extreme caution to avoid overfilling the REFRIGERATION SYSTEM.

A leak test should be conducted after charging but before commissioning. A follow-up leak test should be performed before leaving the site.

Leak Detection:

Under no circumstances should potential ignition sources be used to search for or detect refrigerant leaks. Halide torches or any detectors that utilize an open flame are prohibited.

The following leak detection methods are acceptable for all refrigerant systems:

Electronic leak detectors can be employed to locate refrigerant leaks; however, for FLAMMABLE REFRIGERANTS, the sensitivity of the equipment may be insufficient or may require recalibration. (Detection equipment should be calibrated in a refrigerant-free environment.)

Ensure that the detector does not pose a risk of ignition and is appropriate for the specific refrigerant in use. Leak detection devices should be calibrated to the refrigerant and set to a certain percentage of its lower flammability limit, confirming that the gas concentration does not exceed 25%.

While leak detection fluids are generally compatible with most refrigerants, it is important to avoid detergents containing chlorine, as chlorine can react adversely with the refrigerant and lead to corrosion of copper piping.

NOTE:

Common leak detection methods include:

- Bubble method
- Fluorescent method agents

If a leak is suspected, all open flames must be eliminated or extinguished. In cases where a refrigerant leak necessitates brazing, all refrigerant must be recovered from the system or isolated using shut-off valves in sections of the system away from the leak. The recovery of refrigerant should follow the guidelines outlined in the Removal and Evacuation section.

Recovery:

When removing refrigerant from a system, either servicing or decommissioning, it is recommended good practice that all refrigerants are removed safely.

When transferring refrigerant into cylinders, ensure that only appropriate refrigerant recovery cylinders are employed. Ensure that the correct number of cylinders for holding the total system charge is available. All cylinders to be used are designated for the recovered refrigerant and labelled for that refrigerant. (i.e.

Refrigerant System Servicing

special cylinders for the recovery of refrigerant). Cylinders shall be complete with pressure-relief valve and associated shut-off valves in good working order. Empty recovery cylinders are evacuated and, if possible, cooled before recovery occurs.

The recovery equipment shall be in good working order with a set of instructions concerning the equipment that is at hand and shall be suitable for the recovery of the flammable refrigerant. If in doubt, the manufacturer should be consulted. In addition, a set of calibrated weighing scales shall be available and in good working order. Hoses shall be complete with leak-free disconnect couplings and in good condition.

The recovered refrigerant shall be processed according to local legislation in the correct recovery cylinder, and the relevant waste transfer note arranged. Do not mix refrigerants in recovery units and especially not in cylinders.

If compressors or compressor oils are to be removed, ensure that they have been evacuated to an acceptable level to make certain that flammable refrigerant does not remain within the lubricant. The compressor body shall not be heated by an open flame or other ignition sources to accelerate this process. When oil is drained from a system, it shall be carried out safely.

Decommissioning:

Prior to initiating decommissioning, it is crucial for the technician to thoroughly understand the equipment and its specifications. Safe recovery of all refrigerants is strongly advised. Before commencing the procedure, an oil and refrigerant sample should be collected for potential analysis prior to reusing the recovered refrigerant. It is vital to ensure that electrical power is accessible before starting the task.

1. Familiarize yourself with the equipment and its functionality.
2. Electrically isolate the system.
3. Before proceeding, confirm that:
 - Mechanical handling equipment is available, if necessary, for managing refrigerant cylinders.

- All personal protective equipment is accessible and utilized properly.
- The recovery process is overseen at all times by a qualified individual.
- Recovery equipment and cylinders comply with relevant standards.

4. If feasible, pump down the refrigerant system.
5. If pumping down is not an option, create a manifold to facilitate refrigerant removal from various sections of the system.
6. Ensure that the cylinder is placed on scales before recovery begins.
7. Activate the recovery machine and follow the provided instructions.
8. Avoid overfilling cylinders (do not exceed 80% liquid volume charge).
9. Do not surpass the cylinder's maximum working pressure, even momentarily.
10. Once the cylinders are appropriately filled and the recovery process is complete, promptly remove the cylinders and equipment from the site, ensuring all isolation valves on the equipment are closed.
11. Recovered refrigerant must not be reintroduced into another refrigerating system unless it has undergone thorough cleaning and inspection.

Labeling:

Upon decommissioning, the equipment must be labeled to indicate it has been decommissioned and emptied of refrigerant. The label should include a date and the technician's signature.

Model	Minimum serviceable area (ft2)
PWC-18	n/a
PWC-24	n/a

Ambient Air Limitations

OUTDOOR [Ambient air temperature °F (°C)]					
COOLING				HEATING	
Minimum		Maximum		Maximum	
Dry bulb		Dry bulb		Dry bulb	
67 (19)		115 (46)		75 (24)	
INDOOR [Ambient air temperature °F (°C)]					
COOLING				HEATING	
Minimum		Maximum		Min.	Max.
Dry bulb	Wet bulb	Dry bulb	Wet bulb	Dry bulb	
67 (19)	57 (14)	90 (32)	72 (22)	50 (10)	80 (27)

Thank You for choosing Cold Point products. Our goal is to make sure you remain pleased with your decision to purchase a Cold Point product. If you are in need of assistance that is not available or provided by your local installer/contractor feel free to give us a call, write us, Fax, or e-mail us at:

Cold Point Corp.
510 Henry Street
Rome, NY 13440
Phone:315.339.2331
Fax: 315.339.2358
e-mail: info@coldpointcorp.com

PRODUCT DESCRIPTIONS:

Model PWC

Cold Point 'PWC' Series is direct replacement for Magic Chef "PWC" series chassis. The chassis is a part of a complete system, which consists of the chassis, a wall sleeve/cabinet with louver that is typically built into the building exterior wall, ductwork, and wall thermostat. The chassis contains the compressor, indoor and outdoor heat exchangers, evaporator and condenser motors and fans, electric heaters, and all controls with exception of the wall thermostat. The chassis slides into the sleeve/cabinet for easy removal. The new chassis is dimensionally identical to the original for a fast, easy, and trouble free installation. Proven technology, quality components, careful design and testing, and the latest in reliability and efficiency advances assure long life, user satisfaction, and lower energy cost!

These full-range heat pump units with reverse cycle defrost include thermostatic expansion valves, oversized suction accumulator, electronic defrost control, compressor crankcase heater, high efficiency 'PSC' blower motor & dynamically balanced DWDI blower wheel, and condenser drain pan freeze deterrence.

Consider the extensive list of standard features which includes: Rust-Block* corrosion protection system, condenser fan cycle switch for low ambient evaporator freeze protection, and high-pressure over protection. Cold Point Corp. backs the 'PWC' with a customer friendly one-year parts and labor warranty and five-year compressor warranty, (see Warranty document for details).

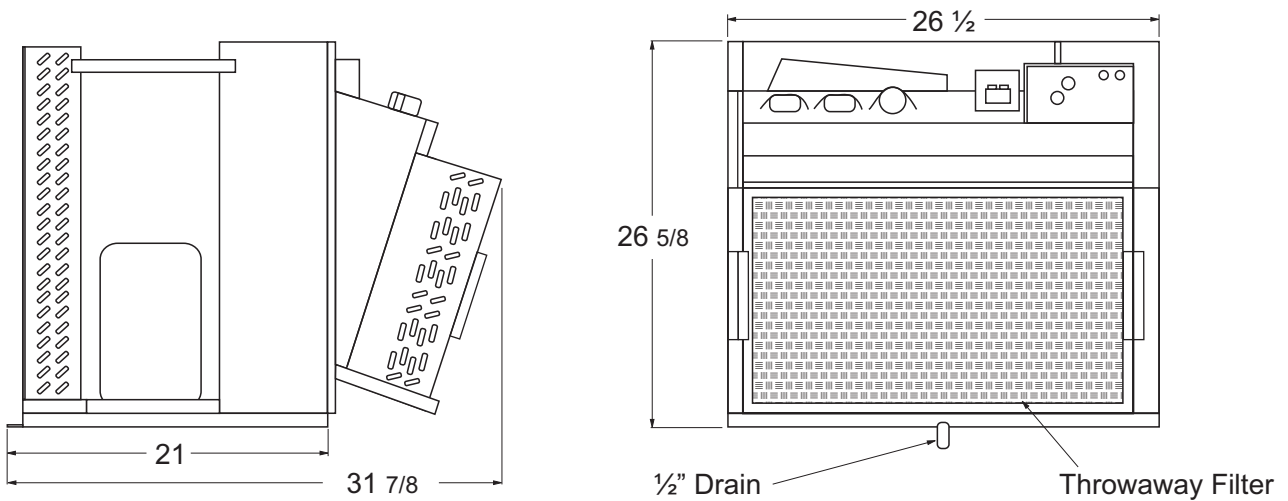

PWC - Pakaged Heat Pump Performance Ratings*

Model	Cooling		Heating		HSPF	Comp. Type
	BTU / h	SEER	BTU / h	COP		
PWC-18	19,300	10.0	18,100	3.1	6.8	Recip.
PWC-24	23,000	9.1	21,000	3.0	6.65	Recip.

Model	Weight
PWC-18	174 lbs
PWC-24	186 lbs

*Rated in accordance with ARI

PWC - Packaged Heat Pump Electrical Specifications

Model	Voltage* HZ / PH	Comp. RLA	Comp. LRA	Evap Fan HP	Evap Fan AMPS	Total AMPS	Min. CKT Ampacity	Max. Fuse Size	Min. Volts
PWC-18	208/230/60/1	7.4	48	1/3	2.2	9.6	12	15	197
PWC-24	208/230/60/1	9.6	60	1/3	2.2	11.8	15	20	197

Installer - General Information

We have designed and manufactured this unit to be safe and trouble free, for use in existing wall sleeves and room cabinets. As the installer of this unit, you play a major role in assuring it's intended performance and customer satisfaction. The important information provided here will help you install the unit correctly and eliminate callbacks.

ATTENTION: Please read these instructions carefully and completely before attempting installation. Unit should be installed by qualified service personnel only. To prevent personal injury and/or death, ensure that all power is disconnected before servicing.

IMPORTANT! Alterations and replacement parts: Altering the product or replacing parts with non authorized factory parts will void the factory warranty and may result in adverse operational performance and/or a possible hazardous safety condition to service personnel and occupants. If you are in doubt as to how to service this unit or where to find factory replacement parts, call *Adirondack-Aire* at 315.339.2331 for assistance

These instructions give information relative to Cold Point 'PWC' series replacement PTAC chassis. Local codes, if different from these instructions, must be followed and supplement or supersede these instructions. Mounting hardware, drain fittings, etc. are not provided with the new unit. Set aside these items during removal of the old unit and reuse or field supply them to install the new unit.

Pre-installation safety instructions:

Failure to follow these instructions can result in fire or electrical shock causing serious personal injury or death and property damage.

Install or locate the unit only in accordance with these instructions.

Use this unit only for its intended purpose as described in this manual.

Stop the installation if unit has damaged wiring, is not working properly, or has been damaged or dropped.

1). Electrical Wiring:

Warning: To prevent personal injury and/or death, ensure that all power is disconnected before servicing. All electrical connections and wiring should be installed by qualified electricians only and conform to the national electrical code and all local codes having jurisdiction. It is the personal responsibility of the customer to retain said electrician conformance with the latest edition of the national electrical code and/or local codes having jurisdiction. Use only recommended wiring ampacity as specified on the unit nameplate and install a single outlet branch circuit. All wiring must comply with all local and national codes.

2). Fuse/Circuit Breaker:

Use type and size fuse as indicated on the rating plate of the unit or use HACR type circuit breaker.

3). Grounding:

Warning: To prevent possible property damage, personal injury or death the unit must be used on a grounded power supply only.

4). The performance and life of the new unit depends on supply voltage that is maintained within proper limit.

5). Electrical supply must have overload fuse/breaker protection as stated on unit rating plate.

THE USE OF EXTENSION CORDS IS PROHIBITED.

Important installation considerations:

The installation must comply with all of the following considerations. **Any deficiencies must be corrected before completing the installation! Failure to comply will create unsafe and/or performance and service life problems and will void the product warranty.**

The chassis is to be used only with metal wall sleeves and room cabinets.

All wiring must comply with 'nec' and local codes.

265 volt units must employ receptacles located within the cabinet or subbase.

Heat pump units will produce condensate in the heating mode. This condensate is drained from the chassis to the outdoors. This is normal so expect and allow for this condensate to drip from the units at temperatures down to 35°f. The building exterior,

sidewalks, and the like will be affected.

The supply air grille must have minor dimension spacing no larger than ½". For adequate airflow the grille must have at least 100 square inches of air outlet area.

The top surface of the cabinet must be at least 1" from the chassis air outlet surface. Outlet air must not be blocked by furniture, curtains, or other obstructions that block airflow or cause air recirculation.

Carpet, furniture, or other obstructions that will hinder free airflow to the unit must not block the return air.

Openings in outdoor exposure louvers or grilles must have minor dimension openings no larger than 1" to prevent contact with moving parts. Airflow must not be obstructed by damaged, clogged, or misaligned louvers. Installations where non-standard louvers are employed must be approved by the factory in advance of replacement chassis installation.

The chassis condenser coil must align with and contact the outdoor louver. If baffles are employed they must be of proper design, size, and location to prevent air recirculation! Failure to do so will degrade or inhibit unit performance and service life. Warranty will be voided if air recirculation is present.

Shrubs, plants, fences, or structures must not obstruct outdoor airflow. Building modifications or structures must not block or obstruct free airflow to the outdoor section of the unit. Units must not be positioned such that the discharge air of one unit blows to the inlet of an adjacent unit.

Outdoor air infiltration around the wall sleeve and chassis must be sealed. Failure to do so will overload the room and may result in comfort and energy cost problems. In cold climates cold air entering around the unit can freeze and burst hot water or steam heat coils causing serious damage to the building and contents!

INSTALLATION:

Work with a helper to avoid personal injury or property damage if the chassis is too heavy or awkward to handle alone. If necessary, provide a drop cloth or other floor protection as removal of the chassis may drop out dirt and/or water as removal proceeds.

REMOVAL OF THE OLD CHASSIS

1). Disconnect the power supply by unplugging the line cord or turning off the power at the circuit breaker panel. If power is shut off at the breaker panel be sure to tag or lock the breaker to prevent accidental or inadvertent re-energizing of the circuit.

2). Remove front wrapper cover to gain access to chassis.

3). Disconnect line voltage wires from compressor contactor.

4). Disconnect low voltage (6-position molex).

5). Remove all necessary hardware to separate chassis from wall sleeve. Slide chassis out from wall sleeve.

BEFORE INSTALLING NEW CHASSIS

1). Inspect the condition of weather seal gaskets for shipping damage. Repair or replace if needed.

2). Inspect the condition of wall sleeve. Repair if needed. Check and clean drain in wall sleeve.

To reinstall unit, reverse the procedure outlined above. Always check to see that the chassis is sealed to the wall sleeve to prevent water and air leakage. Replace or add seals as needed.

IMPORTANT! Dispose of the old chassis in accordance with state and federal regulations! It is illegal to discharge refrigerant into the atmosphere. Use proper reclaiming methods if the refrigerant circuit seal is broken.

CAUTION - Always replace access panels before turning on main power.

ELECTRICAL WIRING:

NOTE: All electrical wiring must be done by a qualified electrician and in accordance with NEC and local codes.

The nameplate on the new chassis indicates the operating voltage, phase, ampacity, maximum over-current protection, and minimum voltage. The power supply must be in accordance with these requirements! Use only HACR type circuit breakers. Inadequate wiring and/or improper electrical supply can cause a safety hazard and/or fire and will likely result in failure of the compressor and other electrical components and voids the warranty. The use of an

extension cord is not allowed.

START-UP, RUN TEST, and OPERATING INSTRUCTIONS:

CRANKCASE HEATER:

The PWC is equipped with a crankcase heater. If the temperature is below 65°F, operate the crankcase heater 24 hours before starting unit.

Time spent to assure proper operation will eliminate call-backs and is time well spent to assure customer satisfaction.

COLD POINT PWC series units are designed to operate from wall mounted thermostats of various designs including mechanical, mercury bulb, and electronic types. The following are general guidelines. Refer to the specific thermostat instructions, and unit wiring diagram for more detail.

Note that many electronic thermostats have built in time delay circuitry. These features will affect the on-off timing of the cooling, heat pump, and fan operation. Some thermostats have programmable features. Refer to the thermostat instruction sheets for details of these various functions.

HEATING OPERATION:

(HEAT PUMP with ELECTRIC HEAT)

*Recommend using 2-Stage thermostat.

Set thermostat system switch to Heat.

Set thermostat fan switch to Auto.

Set the thermostat temperature to a setting warmer than the room temperature.

The compressor, condenser fan and evaporator fan will run during heating cycle and produce warm air.

If thermostat calls for 2nd stage heat, both heat pump and electric heat will run.

The unit will continue to run until thermostat is satisfied.

DEFROST CYCLE:

While running in heat pump mode if the defrost thermostat senses a temperature of 30°F, the interval

between defrost will begin 30/60/90 min. (factory set at 60min.)

At the end of 60 min. run time the condenser fan will stop and the unit will reverse cycle to cooling and electric heat will energize.

The unit will continue to run in this mode until the defrost thermostat reaches 80°F or 10min., which ever is satisfied first.

Unit will resume normal heating operation.

Note: Under certain conditions steam may be seen emanating from the outdoor section during defrost. This is a normal by product of frost elimination.

COOLING OPERATION:

Set thermostat system switch to Cooling.

Set thermostat fan switch to Auto.

Set the thermostat temperature to a setting lower than room temperature.

The compressor, condenser fan and evaporator fan will run during cooling cycle and produce cool air.

The unit will continue to run until thermostat is satisfied.

FINAL INSPECTION:

Do a final visual inspection of the entire installation and confirm the following:

The unit is clean and all tools and construction debris have been picked up.

Room furnishings, carpets, and the like have been replaced in their original position.

All controls and protective devices function properly.

The unit air filter is properly installed.

The unit delivering the proper amount of air.

Unit operation is acceptably quiet and free of vibration.

Nothing is obstructing the supply air and return air to and from the unit.

MAINTENANCE:

Unit performance is maintained at optimum levels by implementing the following preventive measures:

FILTER MAINTENANCE

COLD POINT PWC units are furnished with a 1"X15"X25"throw away type air filter. The unit must not be operated without this filter installed. Filter should be inspected at least every three months, and replaced when dirty. Unit operation becomes very inefficient with dirty filters and system components are stressed. Unit warranty is void if filters are not maintained properly.

Replace only with a filter with an equivalent pressure drop. Certain "High Efficiency" filters are not suitable and use of a non-approved type will Void the PWC Warranty. If in doubt contact the factory for technical help in selecting the proper replacement filter.

CONDENSATE DRAINS:

Condensate drains can pick up lint and dirt, especially with dirty filters. Inspect, and if dirty, clean the condensate drain pan twice a year to avoid the possibility of overflow.

CHECK WIRING:

Annually or as a part of a service maintenance check the tightness of the various wiring connections within the control panel.

FAN MOTORS:

The direct-drive blower and fan motors have permanently sealed, lubricated bearings, and do not require periodic oiling. Adding a few drops of 20W non-detergent oil through the oil ports twice a year may however extend life of the bearings. DO NOT over oil.

MICROBIAL GROWTH:

Microbial growth can occur in air conditioners within the air stream where moisture exists. ASHRAE standards 62-89 recommends that these surfaces be inspected and cleaned to limit contamination. This typically includes surfaces beginning at the finned coil, drain pan, insulation, and fan/blowers

INSPECTING AND CLEANING FINNED EVAPORATOR AND CONDENSER COILS

Coils become externally fouled as a result of normal operation. Dirt on the surface of the coil reduces its ability to transfer heat that can result in comfort problems, increased resistance to airflow and result

in increased operating energy costs. If the dirt on the surface of the coil becomes wet, such as commonly occurs with cooling coils, microbial growth can result which may cause unpleasant odors and serious health related indoor air quality problems. Coils should be inspected at least every six months or more often as necessary. The frequency of the required inspection/cleaning is dependent on the operating hours of the system, filter maintenance and efficiency, and dirt build-up. The following is the suggested method of cleaning coils:

- 1). Disconnect all electrical power to the unit.
- 2). Wear the appropriate personal protective equipment.
- 3). Gain access to the coil section of the unit (both sides).
- 4). Using a soft brush, remove loose debris from both sides of the coil.
- 5). Mix a high quality coil cleaning detergent with water according to the manufacturers instructions. If the detergent is strongly alkaline after mixing (8.5 pH or higher), it must contain a corrosion inhibitor. Carefully follow the cleaning solution manufacturers instructions regarding the use of the product.
- 6). Placed the mixed solution in a pump sprayer or high pressure sprayer. If a high pressure sprayer is used, note the following:
 - A. Maintain a minimum nozzle spray angle of 15 degrees.
 - B. Spray perpendicular to the coil face.
 - C. Protect other areas of the air handler and internal controls from contact with moisture or the cleaning solution.
 - D. Keep the nozzle at least 6 inches from the coil.
 - E. Do NOT exceed 600psi.
- 7). Spray the leaving air side of the coil first, then the entering air side. Use a block-off to prevent spray from going through the coil and into a dry section of the unit and/or system duct-work. Carefully follow the cleaning solution manufacturers usage instructions.
- 8). Thoroughly rinse both sides of the coil and the drain pan with cool, clean water.
- 9). Repeat steps 7 and 8 as necessary.

Before Calling for Factory Assistance

A call to the factory is sometimes necessary for technical support or service/troubleshooting. We are happy to help! Before calling please gather and record the following information so that we are best able to help.

- ___ Unit Model No
- ___ Unit Serial number
- ___ Name of Job or Installation
- ___ Your Name
- ___ Your Company's Name
- ___ Your Company's Address
- ___ Your Company's Phone, Fax, and e-mail
- ___ Room Temperature -DB/WB
- ___ Entering Water Temperature
- ___ Leaving Water Temperature
- ___ Suction Pressure
- ___ Discharge pressure
- ___ Suction Superheat
- ___ Voltage @ contactor
- ___ Amp Reading (clamp-on)
- ___ Your Diagnosis or Question

Cold Point Corp.
510 Henry Street
Rome, NY 13441
Phone: 315.339.2331
Fax: 315.339.2358
e-mail: info@coldpointcorp.com

Records:

Date of Installation _____

Model number _____

Serial number _____

Installing Contractor _____

Address _____

Phone No. _____

Service/Maintenance

Date	Work Performed	BY
_____	_____	_____
_____	_____	_____
_____	_____	_____
_____	_____	_____
_____	_____	_____
_____	_____	_____

Notes: _____

TROUBLESHOOTING CHART

The troubleshooting chart that follows is provided to serve as an aid for identifying malfunctions that may occur. Within the chart are three columns.

1. The **Problems** column describes what the unit is doing.
2. The **Cause** column identifies the most likely sources of the problem.
3. The **Correction** column describes what should be done to correct the problem.

Problem	Heating	Cooling	Cause	Correction
No response to any thermostat setting	X	X	Main power off	Check fuses
	X	X	Defective control transformer	Replace
	X	X	Broken or loose connection	Repair
	X	X	Defective thermostat	Replace
Unit short cycles	X	X	Thermostat or sensor improperly located	Relocate
Blower runs but compressor does not	X	X	Defective compressor overload	Replace (if external)
	X	X	Defective compressor contactor	Replace
	X	X	Supply voltage too low	Correct
	X	X	Defective compressor capacitor	Replace
	X	X	Defective windings	Replace
	X	X	Limit switches open	Check cause/replace or repair
Blower and compressor run but does not cool or heat properly	X	X	Dirty filter	Replace/clean
	X	X	Blower RPM too low (PSC motor only)	Correct
	X	X	Conditioned air loss due to ductwork leak	Repair leaks
		X	Introduction of excessively hot return air	Correct
	X		Introduction of excessively cold return air	Correct
	X	X	Low on refrigerant charge	Locate leak, repair & recharge
	X	X	Restricted metering device	Replace
	X	X	Defective reversing valve	Check/replace
	X	X	Thermostat improperly located	Relocate
	X	X	Unit undersized	Recalculate heat gains/losses
	X	X	Inadequate water flow	Increase GPM
	X	X	Scaling in coil	Clean or replace
		X	Water too hot	Decrease water temperature
X		Water too cold	Increase water temperature	
High pressure switch open		X	Inadequate GPM	Increase
		X	Water too hot	Decrease temperature
	X		Inadequate air flow	Check, clean blower and coil
	X		Dirty filter	Clean/replace
	X	X	Overcharged with refrigerant	Decrease charge
	X	X	Defective pressure switch	Check/replace
High head pressure	X	X	Trash in chiller	Backflush
		X	Low water flow	Increase GPM
	X		Overcharge of refrigerant	Decrease charge
	X	X	Non-condensable in system	Evacuate and recharge
	X	X	Water too hot	Decrease temperature
	X	X	Dirty Filter	Clean/replace
Low suction pressure	X	X	Inadequate air flow	Check, clean blower and coil
	X	X	Undercharged	Locate leak, repair & recharge
	X	X	Restricted metering device	Repair/replace
		X	Inadequate air flow	Check, clean blower and coil
		X	Dirty filter	Clean/replace
Freezestat open	X		Inadequate GPM	Increase
	X		Water too cold	Increase
		X	Defective	Replace